

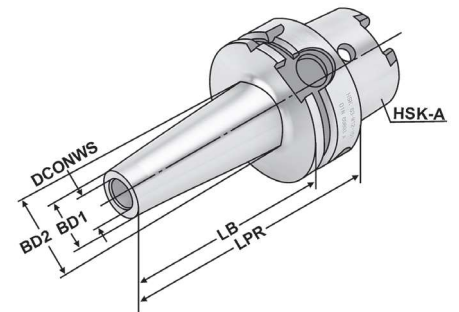

Verwendung:
Zur Aufnahme von Einschraubfräser mit Gewinde.

Application:
For mounting screw-in cutters with thread.

Application:
Pour le serrage de fraises à queue filetée.



ISO 12164 Form A $\leq 3\mu\text{m}$ G2.5 25.000 min⁻¹ RFID Chip H7

5

Bestell-Nr. Order no. Référence	HSK	THSZWS	DCONWS	BD1	BD2	LPR	LB
A63.06.06	HSK-A 63	M6	6,5	10	13	51	25
A63.06.08	HSK-A 63	M8	8,5	13	15	51	25
A63.06.08.1	HSK-A 63	M8	8,5	13	23	76	50
A63.06.08.2	HSK-A 63	M8	8,5	13	23	101	75
A63.06.10	HSK-A 63	M10	10,5	18	20	51	25
A63.06.10.1	HSK-A 63	M10	10,5	18	23	76	50
A63.06.10.3	HSK-A 63	M10	10,5	18	32	126	100
A63.06.10.5	HSK-A 63	M10	10,5	18	37	176	150
A63.06.12	HSK-A 63	M12	12,5	21	24	51	25
A63.06.12.1	HSK-A 63	M12	12,5	21	24	76	50
A63.06.12.2	HSK-A 63	M12	12,5	21	31	101	75
A63.06.12.3	HSK-A 63	M12	12,5	21	33	126	100
A63.06.12.5	HSK-A 63	M12	12,5	21	40	176	150
A63.06.16	HSK-A 63	M16	17	29	29	51	25
A63.06.16.1	HSK-A 63	M16	17	29	34	76	50
A63.06.16.2	HSK-A 63	M16	17	29	34	101	75
A63.06.16.3	HSK-A 63	M16	17	29	36	126	100
A63.06.16.5	HSK-A 63	M16	17	29	43	176	150
A100.06.08.1	HSK-A 100	M8	8,5	13	23	79	50
A100.06.10.1	HSK-A 100	M10	10,5	18	23	79	50
A100.06.10.3	HSK-A 100	M10	10,5	18	32	129	100
A100.06.10.5	HSK-A 100	M10	10,5	18	37	179	150
A100.06.12.1	HSK-A 100	M12	12,5	21	24	79	50
A100.06.12.3	HSK-A 100	M12	12,5	21	33	129	100
A100.06.12.5	HSK-A 100	M12	12,5	21	40	179	150
A100.06.16.1	HSK-A 100	M16	17	29	34	79	50
A100.06.16.3	HSK-A 100	M16	17	29	36	129	100
A100.06.16.5	HSK-A 100	M16	17	29	43	179	150

Empfohlenes Anzugsmoment
Recommended tightening torques
Torques de serrage recommandés

M6	10 Nm
M8	25 Nm
M10	40 Nm
M12	60 Nm
M16	50 Nm

